

NYLON 6/6 (RMS-01) COLOR: NATURAL PART NO.	FLAME RET. (RMS-19) COLOR: NATURAL PART NO.	MOUNTING STYLE
OFSB-4-85-01A	OFSB-4-85-19A	ADHESIVE TAPE
OFSB-4-85-01	OFSB-4-85-19	SCREW MOUNT

MOUNTING RIVETS		
RICHCO RIVET NO.	HOLE DIA.	PANEL THICKNESS RANGE
SR-5045	.201-.205 (5.1-5.2)	.059-.098 (1.5-2.5)
SR-5055		.098-.138 (2.5-3.5)
SR-5065		.038-.077 (3.5-4.5)
SR-5075		.077-.217 (4.5-5.5)
SR-5085		.217-.256 (5.5-6.5)
SR-5095		.256-.295 (6.5-7.5)
SR-5105		.295-.335 (7.5-8.5)

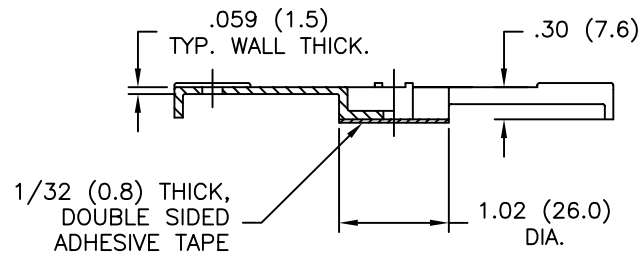

SHEET 1 OF 2

NOTES:

1. ACRYLIC ADHESIVE TAPE (RMS-15).

TITLE: OPTICAL FIBER SUPPORT BASE			DWG IN (MM)		FINAL	
TOLERANCES UNLESS NOTED .XX=±.010 .XXX=±.005 FRAC=±1/64 ANG=±1°			FILE # OFSB-4	DWN: HS/PB	DT: 04-05-95	PART #
D SEE ECN #1019 FOR CHANGES SK 06.23.05			MAT'L: SEE TABLE		CHKD: ENGR:	
C SEE ECN #562 FOR CHANGES SM 01.22.03			RE: RICHCO, INC.		RICHCO INC.	
B UPDATED PRINT & CHANGED FILE NO. SM 02.26.02			PO BOX 804238, CHICAGO, 60680		SEE TABLE	
A NOTE 3 ADDED PB 07.13.95			(773) 539-4060		PRINT TYPE	
REV DESCRIPTION ENGR DATE					CA	

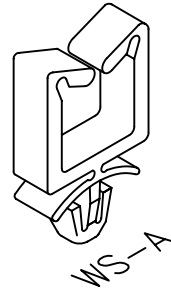
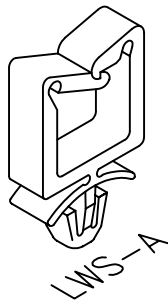
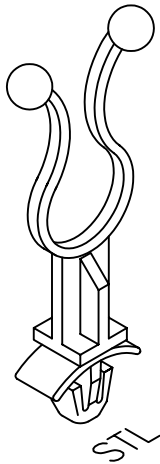
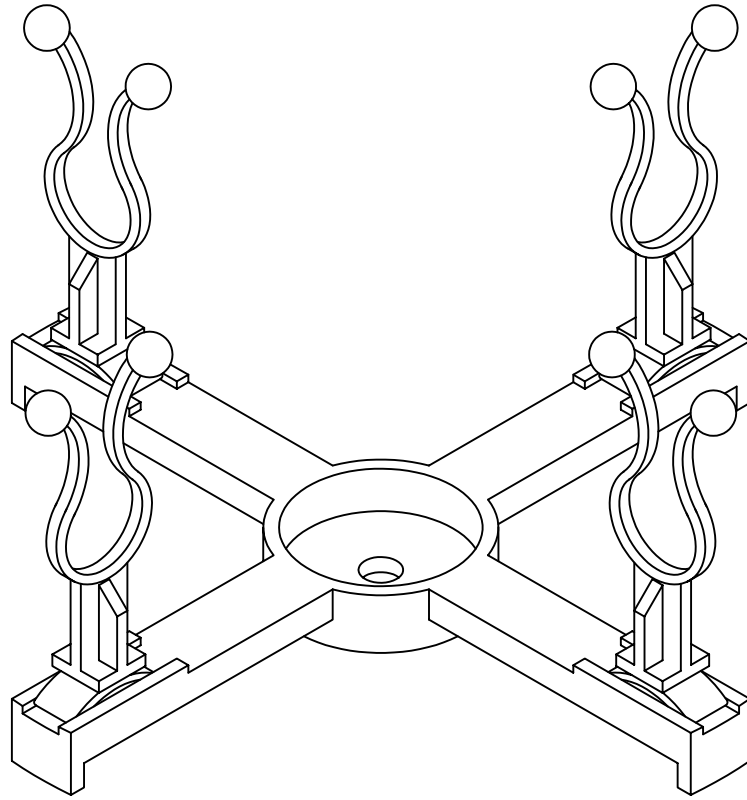

SHEET 2 OF 2

D	SEE SHEET 1	SK 06.23.05
R E V	DESCRIPTION	ENGR DATE

TITLE: OPTICAL FIBER SUPPORT BASE



DWG IN
IN (MM)

FINAL

TOLERANCES UNLESS NOTED .XX=±.010 .XXX=±.005 FRAC=±1/64 ANG=±1°	FILE # OFBS-4	DWN: HS/PB	APP:	PART # SEE TABLE	PRINT TYPE CA
	MAT'L: SEE NOTES	DT: 04-05-95	DT:		
	RE: RICHCO, INC.	RICHCO INC. PO BOX 804238, CHICAGO, 60680 (773) 539-4060			